

ZONCA

L I G H T I N G

ZONICA
LIGHTING

WE CREATE EXPERIENCES, NOT ONLY LIGHTS

Zonca Lighting is a renowned Italian brand specializing in high-quality lighting solutions, with over a century of history and experience.

Known for its elegant designs and exceptional craftsmanship, Zonca Lighting creates a wide range of indoor and outdoor lighting products that blend traditional and modern aesthetics.

Zonca Lighting's collections feature sophisticated and refined styles, combining modern and classic elements to create timeless pieces.

Each piece is meticulously crafted, often by hand, ensuring durability and an exquisite finish.

The brand uses high-quality materials such as blown glass, fine metals, crystals, and premium fabrics. Incorporates advanced technologies to enhance energy efficiency and lighting performance and offers a variety of lighting solutions including table lamps, pendant lights, wall sconces, and floor lamps.

Contract, tailor-made and catalog products: the perfect mix with Zonca Lighting meets the ideas and projects of international architects and interior designers with whom it frequently collaborates, to bring innovative and aesthetically pleasing lighting solutions to residential and commercial spaces.

The attention to technical and aesthetic requirements, the selection of materials, the exclusively artisanal processes, the technical assistance network, make Zonca Lighting a reliable partner to illuminate with an exclusive light every room, every style, every dream.





HAND MADE

BESPOKE
RESTAURATION
TAILOR MADE
ON DEMAND
CUSTOM

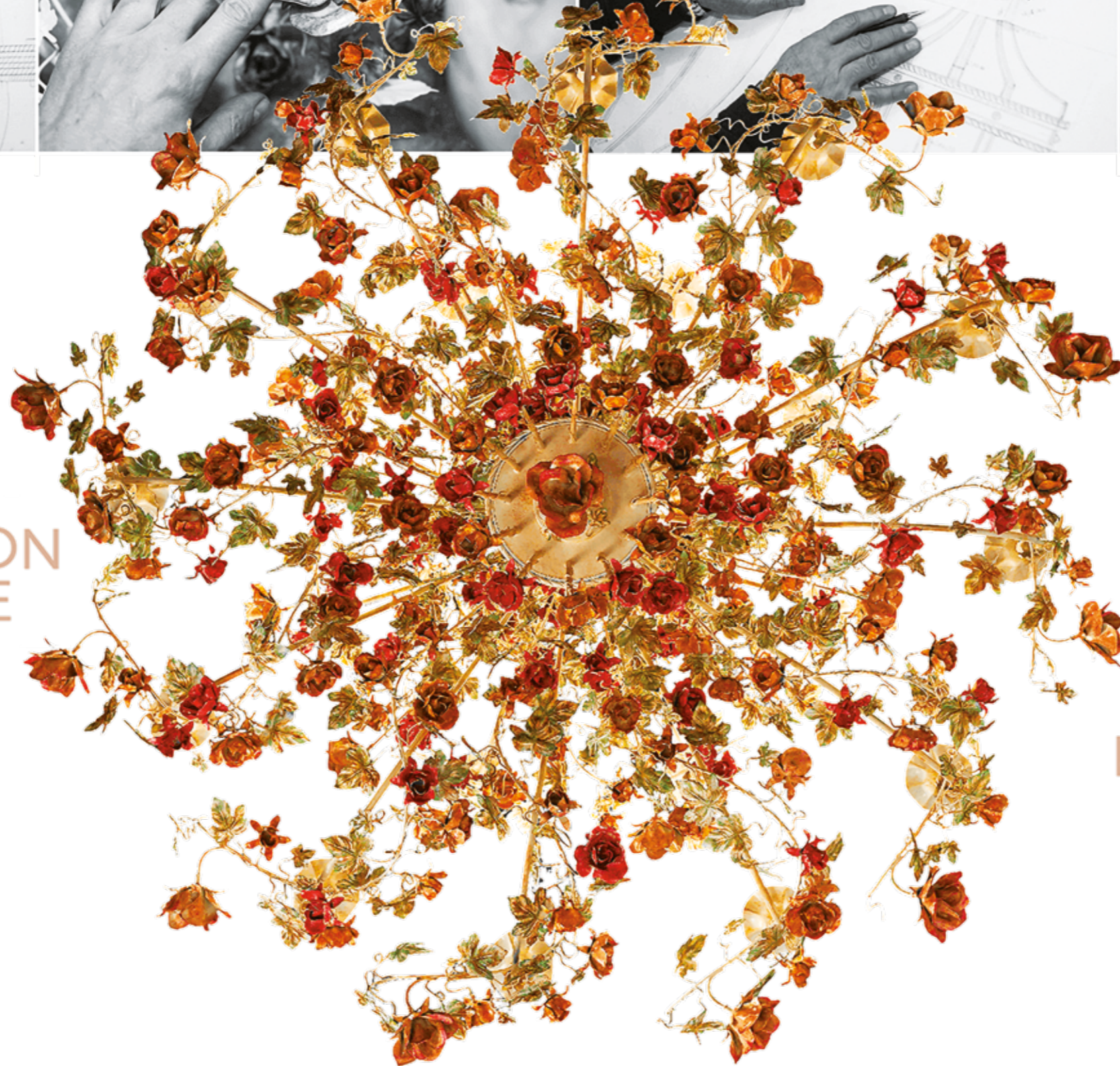

CONTRACT

HOTEL
RESTAURANT
BAR
SPA
RESIDENCE
PRIVATE VILLA
OFFICE
BOUTIQUE

Over a century of lights...

THE OWO – LONDON

Designed by British architect William Young, the War Office was built on the site of the Palace of Whitehall – home for centuries to English monarchs, including King Henry VIII. Built in the Baroque style, the landmark building was completed in 1906 and stood as silent witness to world-shaping events of the 20th century. Influential political and military leaders, including Winston Churchill, walked the corridors and halls of Great Britain's most important seat of power.

The distinctive heritage of the OWO, old war office, has been preserved through six years of restoration and reinstatement of its solemn splendor. Zonca Lighting took part in this engaging operation by creating custom lighting fixtures, with a strong adherence to the specifications of the time, blending industrial and vintage aesthetics.

The designers of '1508 London' and 'The office of Thierry W Despont' modernized these beautiful lines of the early 20th century, and Zonca Lighting, with careful research into the best Italian manufacturing, managed to illuminate the majestic dining halls, lounge areas, private rooms, and suites of this unparalleled building, which, from seat of power, became the most exciting destination in the entire London.



ABBAYE DES VAUX-DE-CERNAY – CERNAY LA VILLE

The rediscovery of the pleasure of countryside life and relaxation away from the hustle and bustle of the city has been reinterpreted by Paris Society, to restore the original beauty to an enchanted place, Abbaye des Vaux-de-Cernay.

The challenge was accepted by Zonca Lighting, in full synergy with interior decorator Cordelia de Castellane and the lighting consultants of Light Q.

Zonca Lighting found the combination of stylistic research that best suits this majestic historical estate and the correct lighting content required, to highlight the materials of exceptional quality, including hand-carved wood, brass castings, and refined silk.

The skilled hands of the artisans of Zonca Lighting forged floor lamps and suspended ones, completely tailor-made, that help to recreate that unique 'country house' charm surrounded by pristine nature, just 45 minutes from Paris.



AMAZÓNICO MONTE-CARLO

Amazonico Restaurant in Monte Carlo is a restaurant renowned for its unique atmosphere and exotic menu. Located in one of the most exclusive locations in the world, this restaurant offers a culinary experience that blends flavors and ingredients from the Amazon with refined and contemporary cuisine.

The restaurant's design, curated by the Spanish studio Lazaro Rosa Violan, is entirely inspired by the Amazon rainforest, with a lush tropical decoration that includes exotic plants, natural wood elements and stone details.

The lighting, created by Zonca Lighting, is also inspired by this style. Artisanal artifacts that spread a soft and welcoming light in the elegant rooms of the location, creating an intimate and relaxing atmosphere. Amazónico Restaurant Monte Carlo is the ideal destination for those seeking an exotic culinary experience in a luxurious and fascinating environment, one of a kind.



VILLA PASSALACQUA – COMO LAKE

Villa Passalacqua captures both the heart and the sight. In fact, it has won first place in the ranking "The World's best Hotel 2023", thanks to its enchanting location in front of Lake Como, its fairytale atmosphere and the magic of its past that intertwines with modern needs. Already a place of meeting, friendship and romance in the 1700s, today this building has undergone a complete restyling and Zonca Lighting has been an integral part of this project. In close collaboration with the owners, the De Santis family and the lighting consultant, Silvia Perego, Zonca Lighting has helped create an evocative atmosphere both inside the Villa and the Palazzo.

The project required months of research and renovation work to bring several chandeliers, wall lamps and floor lamps back to their original splendor.

Focusing on details and respecting authenticity, Zonca Lighting has sought to preserve the elegance and style of the original pieces, some in fine Murano glass, bringing them back to life and making them an integral part of the atmosphere of Villa Passalacqua. In addition to the conservation and restoration work, some lamps from the Garcia collection have also been included, including the Mathilde wall lamp, the Alfred floor lamp and some historic lamps from our production, such as the Arte, Verona and Solitaria table lamps, which make Zonca proud to have contributed to creating a bright and evocative environment, worthy of the prestige of Villa Passalacqua.



HOTEL SPLENDIDO – PORTOFINO

Since 2020, Zonca Lighting has been alongside the designers and the owners for the creation of the lamps and for the restoration of the luminous works of art that were included in the projects Hotel Splendido Mare and Monte. The search for shapes and styles suitable for illuminating the spaces of these iconic environments in the Tigullio "hospitality" panorama, was an energizing journey for the Zonca Lighting team. Splendido Mare is born as a private house overlooking the iconic "piazzetta" of Portofino, now fully restored into a charming hotel, a cozy narrative which blends dolce vita and genuine nautical spirit. The hotel mixes its captivating historic mood with graphic details, playing with patterns and textures for seats, fabrics and crystals, recalling that old world of fishermen who once lived this little village. The luxurious rooms and suites, the elegant halls, each paradise corner are marked by the exclusive design of Festen Architecture Paris, in collaboration with Zonca Lighting for all the hotel lightings. Not just the new lamps with classic and essential shapes: Zonca Lighting, thanks to its experience and craftsmanship, oversaw the careful restoration of the precious historic lamps, now shining in a new intriguing light. Renowned for its elegance and breathtaking views of the Ligurian Sea, Hotel Splendido Monte combines classic charm with modern comforts. Spacious and elegantly decorated, with marble bathrooms, private terraces and stunning sea views, preserving its legacy as the "Grande Dame of Portofino," the iconic Splendido Hotel has reopened in the first phase of its multi-phase renovation, curated by Martin Brudnizki Design Studio, MBDS. For this project, Zonca Lighting was honored to oversee the delicate process of restoring the sumptuous 19th-century works of art, wood chandeliers and floor lamps, lanterns and handmade ceramic table lamps, that illuminate the entire location. The epitome of Italian luxury and hospitality, it pays homage to traditional techniques and local craftsmanship, yet is decidedly contemporary. Both projects are the emblem of Italian luxury and hospitality, paying homage to traditional techniques and local craftsmanship, which have allowed Zonca to further improve in the field of functional and aesthetic restoration in the spirit of sustainability and the protection of Italian artistic heritage!



TEATRO VALENTINO GARAVANI – VOGHERA

The origins of the Voghera theatre date back to the early 19th century, when, by the will of a society of individuals and important families of the city, it was decided to incentivize art and theatrical performances in the important Voghera of the time.

The ambitious project of the construction of a social theatre and the purchase of the buildings that were to host the new structure and the interior spaces were entrusted to architect Felice Moraglia in 1836, and later to architect Gioacchino dell'Isola-Molo del Borghetto from Turin in 1841. After three years of intense construction and furnishing works, on 11 July 1844, the king of Sardinia Carlo Alberto granted the royal patents that ratified the privileges and prerogatives of the social theatre.

It is clear from this historical context how important the construction of this building, which was inspired by the royal theatres of northern Italy, must have been for the city. The sumptuous furnishings and lighting were commissioned to the best artisans of the time, already suppliers to the Real Casa. Among all the artefacts, what stands out is the Astrolampo, the name of the large chandelier that dominates the theatre, made by the workshops of Knight Giacinto Ottino, producer of the greatest lighting works of the time.

After the splendour of the early 20th century, a gradual decline led the theatre to its definitive closure in 1986. In 2018, its restoration was finally proposed thanks to private and public funding.

Zonca Lighting was involved in 2019 in an ambitious project of study and functional and aesthetic restoration of the artefacts related to lighting. An accurate historiographical study with the archives of the municipality of Voghera and a scientific study with the University of Pavia allowed to formulate the final report which received the approval of the superintendence of cultural heritage to proceed with the restoration works.

At the end of 2023, after years of restoration of the Astrolampo and the other lamps that illuminate the foyer and the ticket office, the Social Theatre of Voghera came back to life, now named 'Teatro Valentino Garavani', in honour of the famous fashion designer originally from the same city.



LA RESERVE HOTEL & SPA – RAMATUELLE

La Réserve Ramatuelle is a luxury hotel located near Saint-Tropez on the French Riviera, renowned for its exceptional location and breathtaking views of the Mediterranean.

This 5-star property comprises a hotel, a spa and a private villa, offering an intimate and serene setting away from the hustle and bustle of nearby towns.

The hotel features a wide variety of rooms, suites and villas designed to blend seamlessly into the natural surroundings.

Each accommodation offers stunning sea views, with interiors reflecting a chic and modern design inspired by the 1950s French Riviera with soft blue and white tones that characterize La Réserve Ramatuelle in every corner.

Zonca Lighting, in collaboration with French decorator Jacques Garcia, has expertly illuminated the suites, the lounge and the two-Michelin-starred restaurant, La Voile, handcrafting light sculptures that perfectly frame every environment of this stunning location.



L'OSCAR HOTEL – LONDON

L'Oscar Hotel is a luxurious 5-star boutique hotel, housed in a former Bloomsbury church in the Holborn district, that pays tribute in name and style to the Irish writer Oscar Wilde. The historical building dates back to the early twentieth century and was rediscovered, by the current owner and by the architect Jacques Garcia, who found it almost randomly, while walking around London. Each of the 39 rooms is unique in its eclectic design. The identifying traits are the recurrent motifs of birds, 500 in the whole building, that perched on lamps and ceiling lights custom made by Zonca Lighting. The most iconic and spectacular is certainly the chandelier that runs from top to bottom all the seven floors of the hotel with an endless series of hummingbirds, parrots, and plover in a spectacular spiral. A vision that alone is worth the stay in what is a candidate to be among the most prestigious luxury hotels on the international scene.



HOTEL MARIA CRISTINA – SAN SEBASTIAN

The Maria Cristina Hotel in San Sebastian is an institution in the Basque country's hospitality circuit. Since its inauguration in 1912, it has remained closely bound to the history, vicissitudes and cultural life of the city of San Sebastian. For its one hundredth anniversary, the property entrusted the HBA design studio in London with the project of restyling the interiors of this five-star luxury hotel. Zonca Lighting was entrusted with the creation of unique tailored pieces so as to furnish the hotel with a classic style, without renouncing the introduction of design details. The beautiful interiors are inspired by the Belle Époque and stand out for their majestic columns, nineteenth-century portraits, refined silk brocades and the spectacular armed chandeliers. The decor is surprisingly eclectic and the crystals of the ceiling chandeliers and the silks of the lampshades on the walls complete the atmosphere of this prestigious luxury hotel with a 'Made in Italy' touch.



HOTEL DANIELI – VENICE

Charming and luxurious, Hotel Danieli Venice is located in one of the most exclusive locations in the city. The interior is richly decorated with artisan glass chandeliers, precious fabrics and tapestries, hand-crafted marble columns and a sublime period decor. Hotel Danieli Venice is the apotheosis of the most exotic, aristocratic and exclusive Venice imaginable, it's no coincidence that it is considered among the top 20 most iconic hotels in the world. Zonca Lighting, in partnership with the interior designer Jacques Garcia, illuminated the hotel's rooms, customizing every detail and recreating a historic atmosphere. The lighting of the historic suites, designed by the architect Pierre Yves Rochon, is also signed by Zonca Lighting. Soft lights and lampshades, in line with the velvet on the furnishings, create a particularly romantic, elegant and refined setting.



THE MAXWELL RESERVE HOTEL – SINGAPORE

Situated in the heart of Singapore on Murray Terrace, a 100-year-old British colonial building, Maxwell Reserve, a Marriott Bonvoy Hotel, is a masterpiece conceived by owner Satinder Garcha and crafted by world-renowned French designer Jacques Garcia, elegantly embodying decadent European grandeur infused with cosmopolitan sophistication.

For this unique venue, Zonca Lighting provided all decorative lighting, custom-crafted to perfectly complement the stunning and luxurious setting.

True to its values of roots, glory and pride, Maxwell Reserves prides itself on indulging its guests with thrilling hospitality in its rich and entertaining ambiance, adorned with the owner's museum-quality family artifacts dating back to 1709, illustrating Garcha's passion for polo and the glorious history of Singapore and Royal India.



GRAND HOTEL TREMEZZO – COMO LAKE

Lake Como offers one of the most enchanting and sought-after views in the world. On these suggestive shores stands the Grand Hotel Tremezzo, one of the most beautiful and ancient luxury hotels in the area; an authentic Art Nouveau palace, with period interiors and attention to every detail. Like a treasure chest, the Grand Hotel Tremezzo hides precious jewels: refined rooms, panoramic suites and historic suites. Zonca Lighting took care of the details and lighting of the Emilia Suite, the latest addition to the Grand Hotel Tremezzo. Located in the adjacent Villa Emilia, a historic eighteenth-century palace, it is characterized by delicate colors in shades of green, blue and gray. It is completely independent from the main body of the hotel and offers absolute privacy, for a truly romantic stay. For the Emilia Suite, Zonca Lighting chose to create an atmosphere of soft lighting that alternates with the iconic creations of the Jacques Garcia collection. A touch of pure poetry for an unforgettable location that also has a private and direct access to the scenic T Spa.

Zonca Lighting is also present with its collection of custom-made battery table lamps on the magnificent "Terrazza Gualtiero Marchesi", the very elegant restaurant of the Grand Hotel Tremezzo with a breathtaking view of Lake Como.



EXCELSIOR HOTEL GALLIA - MILAN

The Excelsior Hotel Gallia Milan returned to being an integral part of Piazza Duca D'Aosta following the architectural and interior design project by architect Marco Piva. Today the hotel, with its nearly 100-year tradition, is considered as one of the most advanced "receptive machines" in the world. Protagonist is the lighting project realized by Zonca Lighting, that has installed thousands of light sources, many of which were custom made, such as the "Meneghina" and "X" lamps. "X", for example, is inspired by the lozenges that characterize the intrados of the ancient building's loggias and embedded in various areas throughout the structure, from the staircase to the elevators. "Meneghina", on the other hand, projects a play of light in space through linear cuts, embellishing the 100-meter internal "Promenade" which connects the common spaces of the historical wing to the new building's Grand Hall, giving to the environment a unique image.



HOTEL SELMAN - MARRAKECH

Superb, elegant, harmonious and classy: the Selman Hotel Marrakech is a refined five-star hospitality location, overlooking the Atlas Mountains and the captivating magic of Marrakech. Unmistakable is the touch of the French architect Jacques Garcia, who conceived an atmosphere far from international standards that combines artistic vision and the North African Moorish style with the passion for the owners' horses. Every corner of this incredibly particular luxury hotel depicts references and details of the equestrian world, large chandeliers, sinuous chaises longues, purple upholstery and imperial antique gold follow each other in style design that draws on Arabic culture and art. In such a particular context, Zonca Lighting chose to include a classic from the Jacques Garcia collection: "Alfred", the floor lamp with gilt bronze finish and ivory lampshade, a floor lamp that illuminates the common areas of this precious boutique hotel with a suffusing light.



SPLENDID HOTEL – VENICE

With its central but isolated position, just steps from the historic Piazza San Marco and the Rialto Bridge, Splendid Venice provides visitors a true Venetian experience. Rich hues, priceless textiles, and exquisite architectural elements abound at this hotel, which also has a private dock for gondolas and water taxis and breathtaking views of the canal.

The lamps by Jaques Garcia for Zonca Lighting were selected specifically for this breathtaking spot. In the hotel, "Moliere", "Boileau", "Diderot", and "Mòlitor" are the actual stars, offering a genuine sense of Venetian magnificence.



CHATEAU MONFORT HOTEL – MILAN

Entirely inspired by the concept of fairy tales, Chateau Monfort inaugurated an original typology: the Urban Château, or rather a context characterized by strong identity, fantasy and imagination. It is the result of a long design by the two-set design Elisabetta Frazuoli and Francesca Fezzi of FZI Interiors along with the architect Sofia Vedani, hotel owner. A silent and respectful restoration work of the original structure which involved Zonca Lighting in the delicate phase of lighting. The designers chose to characterize the light of the entrance using streetlamps so as to evoke an atmosphere from the past and Zonca Lighting fulfilled their request by reproducing the original style of the lamps to illuminate the whole structure from the Art Nouveau entrance to the lobby, from the suites to the meeting room in the ancient dungeons of the palace. Nothing has been left out in Château Monfort.



LA RESERVE HOTEL & SPA - PARIS

L' Hotel is located at 42 Avenue Gabriel in a Haussmann villa between Avenue Montaigne and rue Faubourg Saint Honoré with beautiful outdoor spaces and a view of the Eiffel Tower. The French entrepreneur Michel Reybier chose the designer Jacques Garcia so as to give unique touch to his latest creation on the Champs-Élysées. The interiors are decorated with antique furniture, damask wallpaper and velvet upholstery. Each of the 40 rooms look like a small treasure chest with gold colours and shades. The reflections of the mirrors emphasize the natural light but also the play of light made by Zonca Lighting specifically for this structure, creating tailor-made solutions in every ambient. In addition to a luxurious spa with indoor pool, the hotel features a library and a contemporary French restaurant with two Michelin stars, Le Gabriel.



HOTEL EDEN - ROME

Located in an enviable position, between the Piazza di Spagna, the Villa Borghese and Via Veneto, the Hotel Eden Rome is considered the best of luxury hospitality in the capital, it dates back to 1889. Since the moment it opened, was visited by royalty, diplomats and celebrities like the King Alfonso XIII of Spain, Umberto of Savoy and Federico Fellini who here, in the middle of Dolce Vita, loved to give international interviews, surrounded by a spectacular view of the center of Rome. The setting goes beyond 5-star and the meticulous restyling designed by the French architects, Bruno Moinard & Claire Bétaille of 4BI & Associées agency, focused everything on the Italian-ness of the spaces and colours. The touch by Zonca Lighting, who oversaw the lighting of the suites, is perceived in the atmosphere that recreates an antique aura, intertwined with contemporary taste. In the interiors, white marble, fabric wallpaper, Murano glass, all in gold, black, grey with touches of red and green, each intervention has been done with exclusive materials.



NOMAD HOTELS – NEW YORK – LOS ANGELES – LAS VEGAS

Mathilde, Violetta, Diderot: the most classic of the Zonca Lighting collection, embellish the rooms and spaces of The NoMad Hotels in New York, Los Angeles and Las Vegas. In these luxury hotels the Jacques Garcia style breathes through every detail, each room is furnished with custom furnitures, designed and decorated by hand, and with original works of art. The high ceilings characterize the common areas offering a meeting place to dine and socialize in an atmosphere emphasized by the lighting signed Zonca Lighting. In particular, the library of The NoMad Hotel in New York is a game of art, culture and lights like nowhere else in the world. From the lobby to the restaurant, from the bathrooms to the library, The NoMad Hotels are an art and surprise gallery in which Zonca Lighting wall and floor lamps are made unmistakable by the classic lampshades in fine fabric.



THE ALPINA HOTEL – GSTAAD

Inge Moore and Nathan Hutchins from Muza Lab led the design team that worked at the 5-star-superior Grand Hotel the Alpina Gstaad, set in spectacular scenery in the most glamorous location in Switzerland. Design embraces the legend, but at the same time embraces modernity and a generous array of idiosyncratic delights, offering an extraordinary connection with the Alpine world outside and, inside, the individuality reminiscent of a very special private residence. For this exclusive destination, Zonca Lighting has developed a lighting project able to enhance every single detail, to uniquely embody the sophistication of the Swiss hospitality. A sophisticated play of lights that permeates the atmosphere between original and contemporary local materials that delicately combine with authentic antique wood.

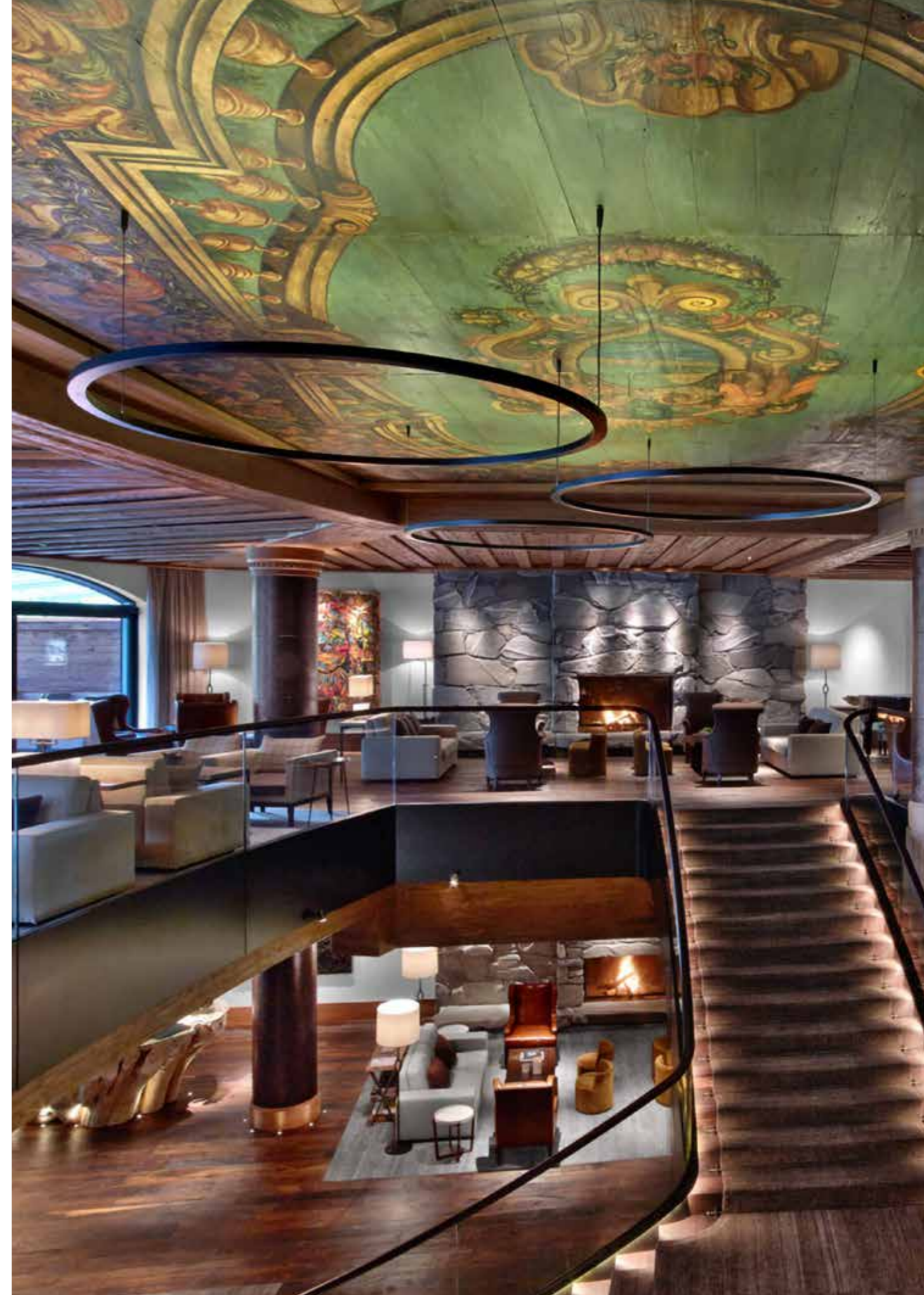

THE DUXTON RESERVE HOTEL – SINGAPORE

The award-winning Duxton Reserve, Autograph Collection is perfectly situated in the heart of Tanjong Pagar Island's city centre and the heart of Chinatown, where business, socialising, dining and nightlife take centre stage.

The Urban Redevelopment Authority Architectural Heritage Award-winning building's original design features a diverse mix of Chinese, Malay and European elements. Guests are in for an elegant surprise when they enter the hotel, which features large theatrical gold fans and bold shades of black, gold and yellow, layered with oriental screens and calligraphic wallpaper from Anouska's personal collection.

In keeping with the rich Asian history, yet presented with Anouska Hempel's luminous vision, Duxton Reserve, Autograph Collection boasts 49 guest rooms and suites. Zonca Lighting has helped illuminate each one with its custom creations, designed by Anouska Hempel herself, making each one completely unique, so no two are exactly alike.



ANNEX BEACH – CANNES

The Annex Beach Cannes restaurant, situated in the heart of the Croisette, has been completely restyled during the extensive refurbishment of the interior to which Zonca Lighting contributed with an ambitious lighting project. The restyling of the Annex Beach Cannes is yet another successful project by Zonca Lighting in collaboration with Jacques Garcia, the internationally renowned architect and interior designer.

The choice, in particular, fell on the Alfred floor lamps and Mathilde wall lights for the Annex Beach Cannes, both designed by Jacques Garcia, conveying a warm, welcoming light which fits in perfectly with the sophisticated atmosphere of the restaurant.

Lastly, the sophisticated and elegant Zonkita battery-operated lamps, featured in the restaurant and on the private beach, conjure up a glamorous atmosphere, creating an emotion-filled, atmospheric backdrop as soon as sun sets on the Croisette.



HÔTEL BARRIÈRE LE FOUQUET'S - PARIS

In the 1930s Hotel Barrière Le Fouquet's, the Champs-Élysées' famous restaurant, was a place frequented by stars, directors, prominent personalities and artists. Later the structure has been widened incorporating the luxurious adjacent buildings and thus giving life to the Hôtel Barrière Le Fouquet's. For the project were in charge the architect Edouard François and the Parisian designer Jacques Garcia involved once again, ten years later, for a second restructuring, inspired by the rich legacy of the French film industry. Zonca Lighting elaborated numerous tailor-made solutions for this prestigious project, as well as selecting, supplying and installing lamps and chandeliers from the "Les Grands Classiques de Jacques Garcia" collection, the work of the Parisian designer, which is produced exclusively by Zonca Lighting. Situated in a privileged position – VIII Arrondissement, in the heart of the 'rive droite' – and an architectural and technological icon, the Hotel Barrière Le Fouquet is the luxury location for an authentically Parisian experience.



MONSIEUR GEORGE HOTEL & SPA – PARIS

Located on the Champs-Élysées, with spectacular view of Paris, this 5-star boutique hotel offers 46 rooms with a sensual and elegant aura. The interiors are characterized by two predominant chromatic shades: dark green and black in the rooms and lobby and pure white, totally at odds, in the suites. Zonca lighting has created for this project special lighting installations entirely customized and attention to detail. In the restaurant we find suspension in transparent glass craft and round structure, while the rooms and suites are illuminated by brass wall lamps and slender wooden floor units with minimal-chic design. The result is an exclusive environment, from which transpires a surprising atmosphere of comfort and intimacy.

The luxurious spaces are marked by the exclusive design of Anouska Hempel, in collaboration with Zonca Lighting for all the hotel lightings.



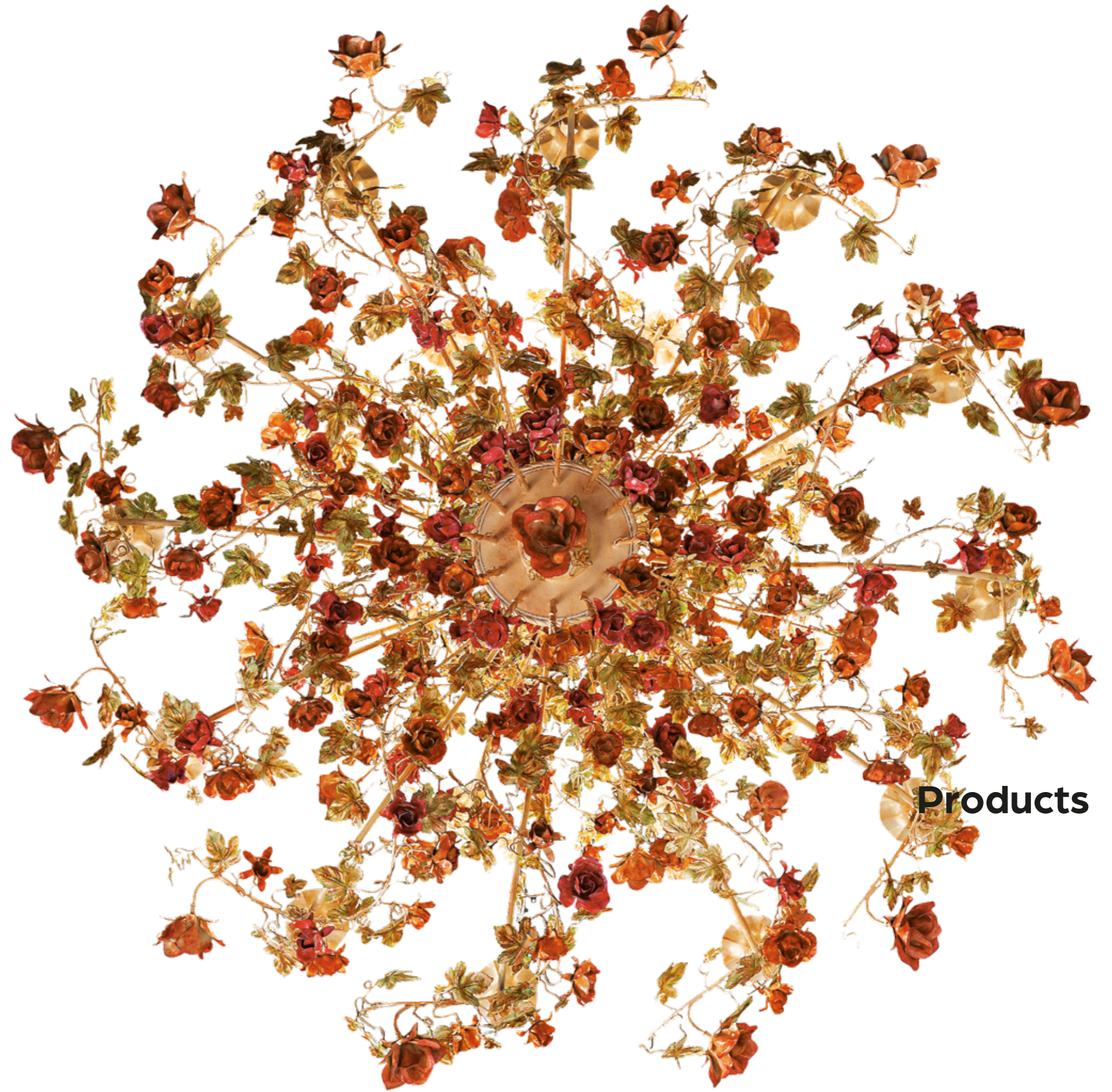



























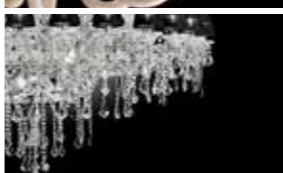























Products























ALPHABETICAL INDEX

ACQUA	118	MONACO	114
AMANTIDE	68	NASSO	113
ATMOSFERA	100	PARO	112
AURA	116	RADIANT	64
BALLERINA	98	SEMPRE	102
CHIO	110	SOFFIO	82
CLASSICA	80	SOGNI	119
CORINTO	104	STELLATA	66
DINAMICA	122	STONE	106
DOGE	88	VALENCIA	107
IDRA	108	VIENNA	117
IMPERATRICE	86	VIOLANTE	76
LANTERNA	94	QUADRO	120
MARE	96	ZONKITA	124

FIGURATIVE INDEX

	RADIANT 64						
	STELLATA 66						
	AMANTIDE 68						
	VIOLANTE 76						
	CLASSICA 80						
	SOFFIO 82						
	IMPERATRICE 86						
	DOGE 88						

	LANTERNA 94					
	MARE 96					
	BALLERINA 98					
	ATMOSFERA 100					
	SEMPRE 102					
	CORINTO 104					
	STONE 106					
	VALENCIA 107					
	IDRA 108					
	CHIO 110					

	PARO 112					
	NASSO 113					
	MONACO 114					
	AURA 116					
	VIENNA 117					
	ACQUA 118					
	SOGNI 119					
	QUADRO 120					
	DINAMICA 122					
	ZONKITA 124					

RADIANT

Special pendant lamp, metal structure in brass with bronze video 70 finishing and transparent grooved glass diffuser.

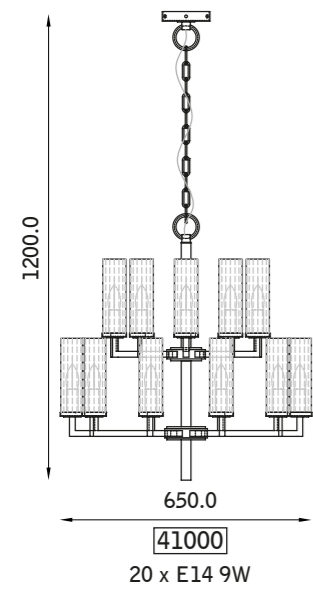

STELLATA

Modular lamps with quadrihedra available in combinations chrome (102) + transparent glass TR, gilded (145) + transparent glass TR, dark bronze (127) + transparent glass TR, or in other colours of your choice.

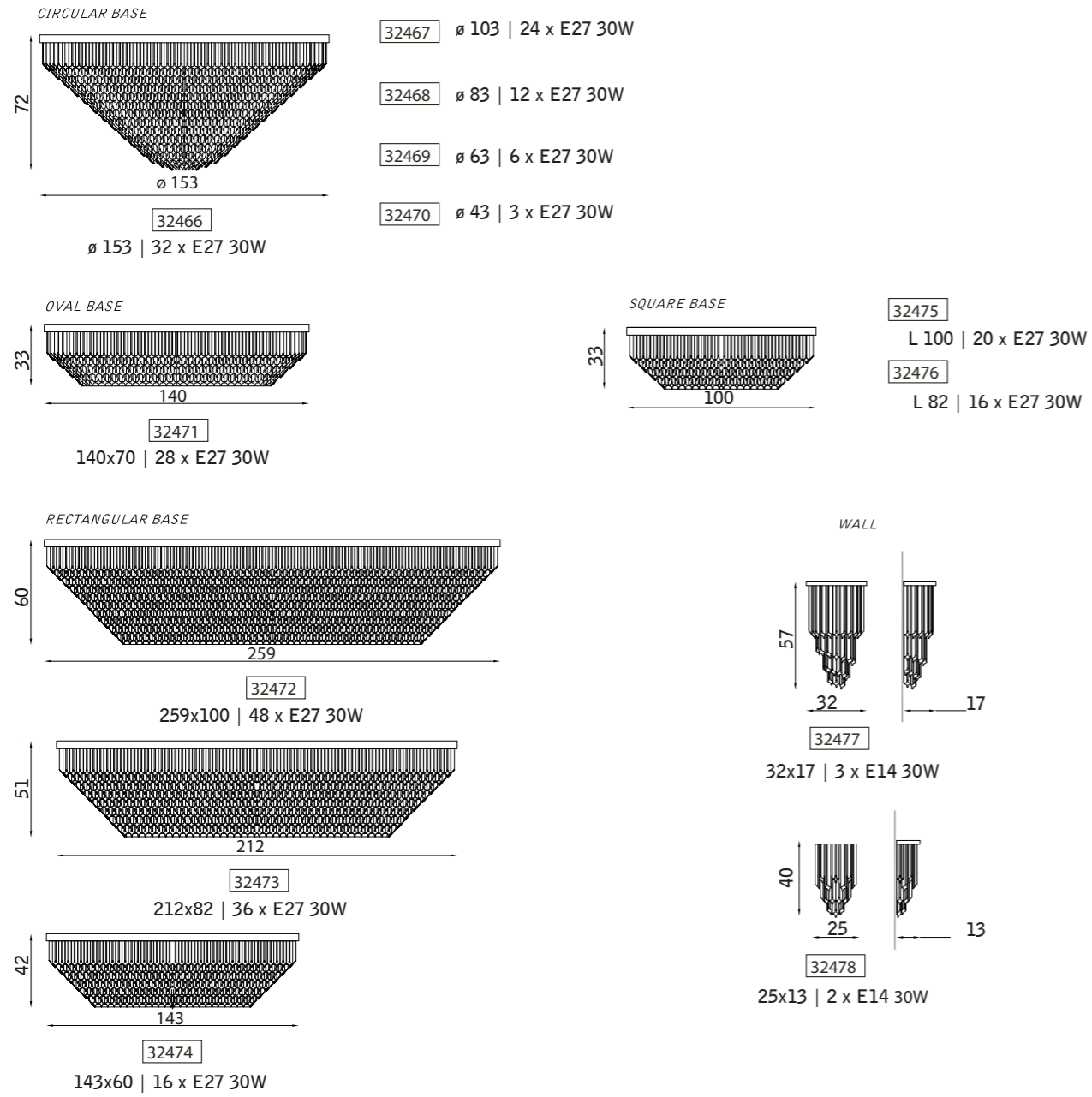

AMANTIDE

Metal lamp available in matt ivory (187) with smooth ivory lampshade (803), matt brown (188) with smooth peach rose lampshade (826), or in satin brass (120) finishes with smooth black inside gold lampshade (00010), satin nickel (101) with smooth white lampshade (800), or in other colour combinations of your choice.

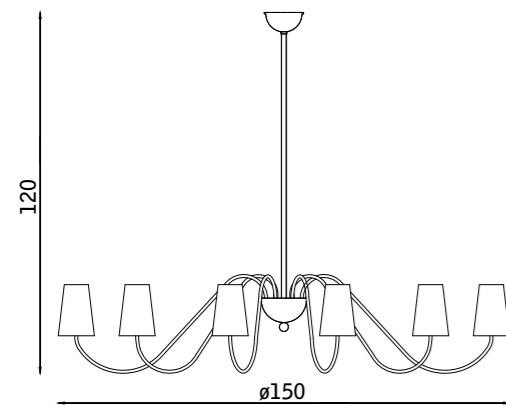

31192
12 x E14 9W

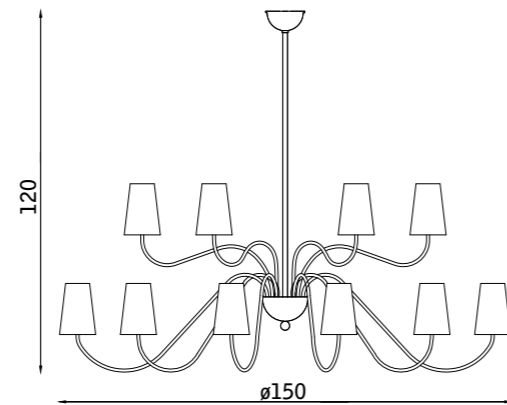

31193
18 x E14 9W

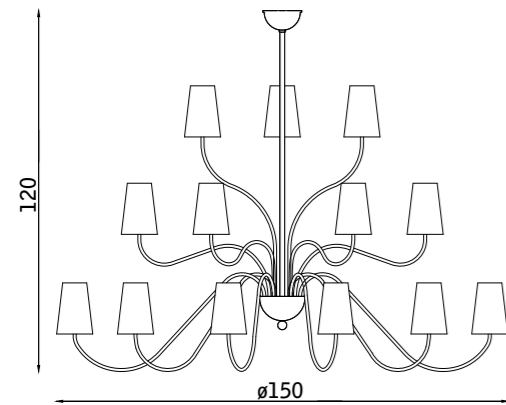

31194
21 x E14 9W

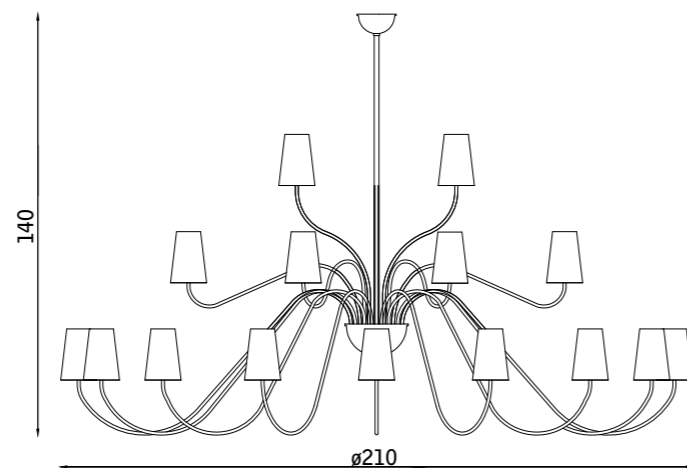

31195
28 x E14 9W



AMANTIDE

Metal walls lamps available in matt ivory (187) with smooth ivory lampshade (803), matt brown (188) with smooth peach rose lampshade (826), or in satin brass (120) finishes with smooth black inside gold lampshade (00010), satin nickel (101) with smooth white lampshade (800), or in other colour combinations of your choice.

*Example of a customized model with a white plaster finish and lampshades in Pierre Frey fabric, Dampierre Gorgone - code L4563004.

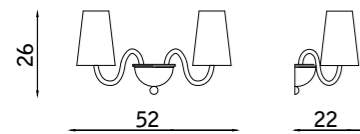

31189
2 x E14 9W

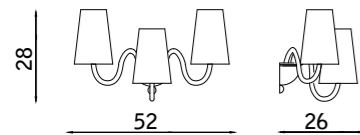

31190
3 x E14 9W

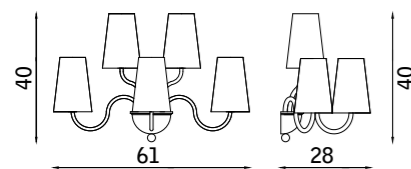

31191
5 x E14 9W



AMANTIDE

Metal lamp available in matt ivory (187) with pleated ivory lampshades (803), matt brown (188) with pleated peach rose lampshades (826), or in satin brass (120) finishes with pleated black inside gold lampshades (00010), satin nickel (101) with pleated white lampshades (800), or in other colour combinations of your choice.

*Example of a customized model with a white plaster finish and lampshades in Pierre Frey fabric, Dampierre Gorgone - code L4563004.

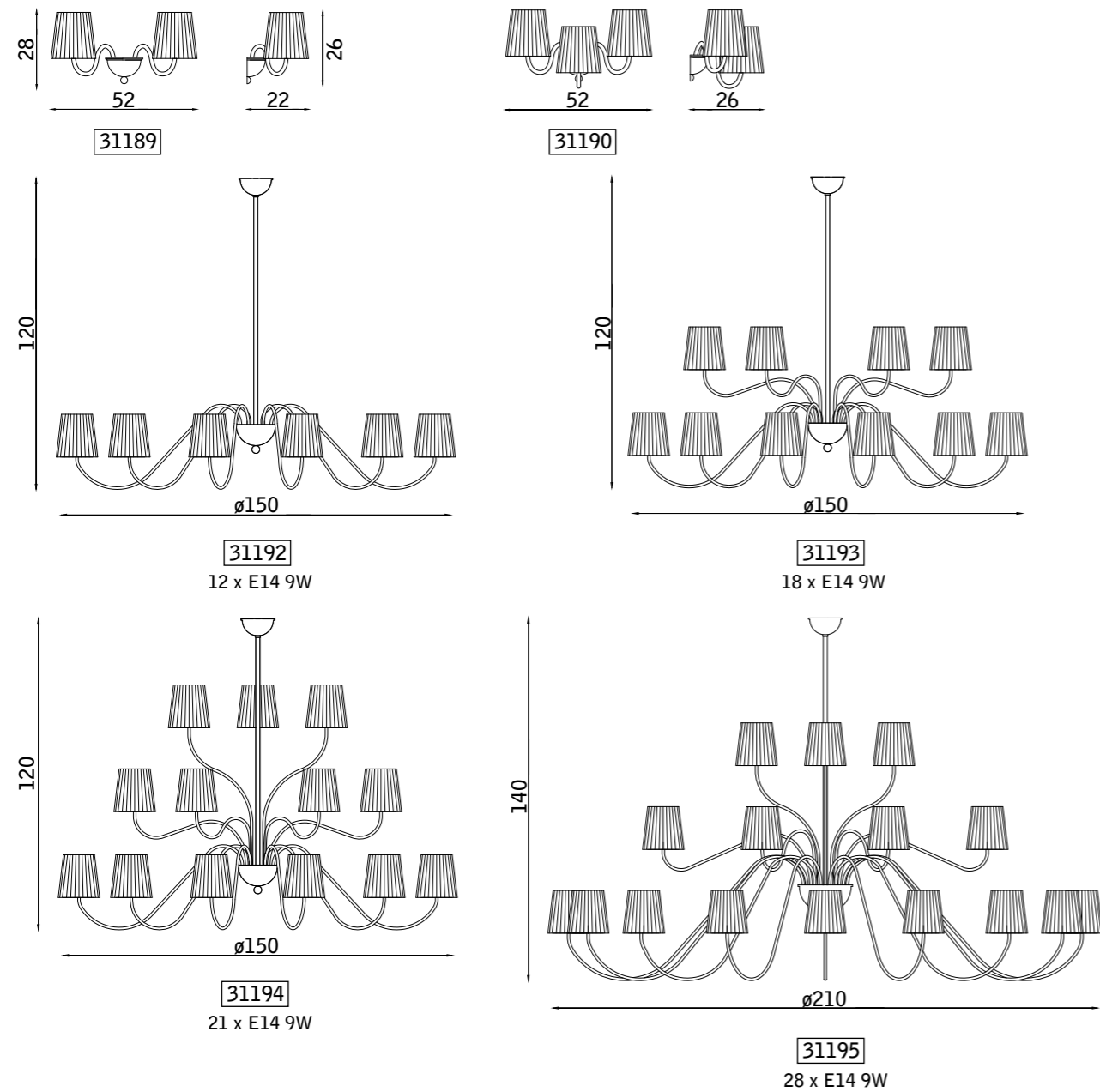



VIOLANTE

Venetian chandelier available in chrome (102) + smoked glass FM with white pleated lampshade (090), chrome (102) + transparent glass TR with brown pleated lampshade (095), gold (145) + amber glass AM with ivory pleated lampshade (099), gold (145) + amethyst glass AT with ivory pleated lampshade (099) or in other colors of your choice

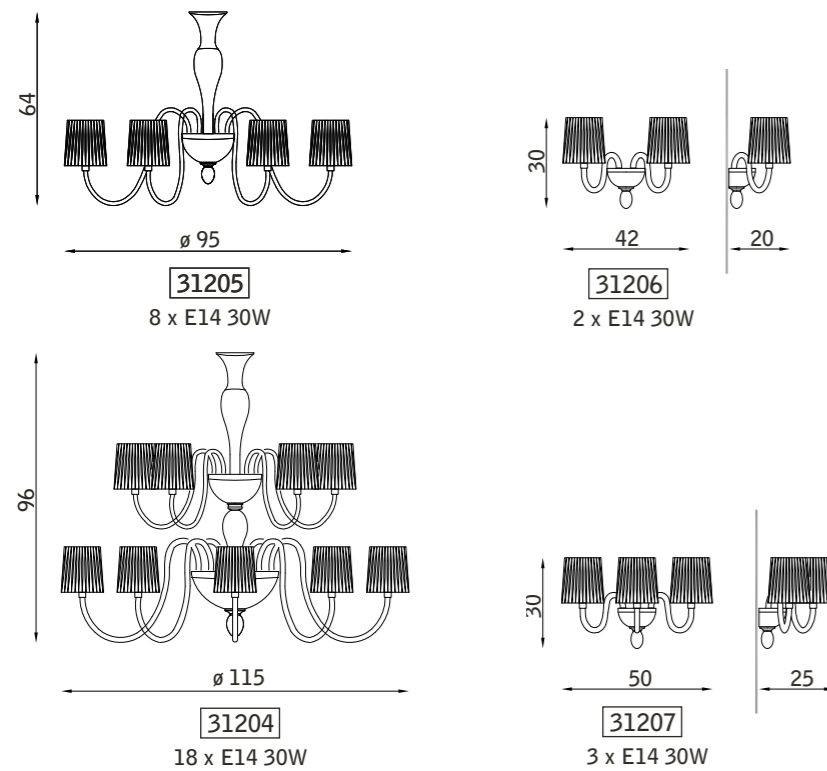



CLASSICA

Brass lamp with satin finish brass (120), polished brass detailing (106), lead crystal and ivory pleated lampshades (083).

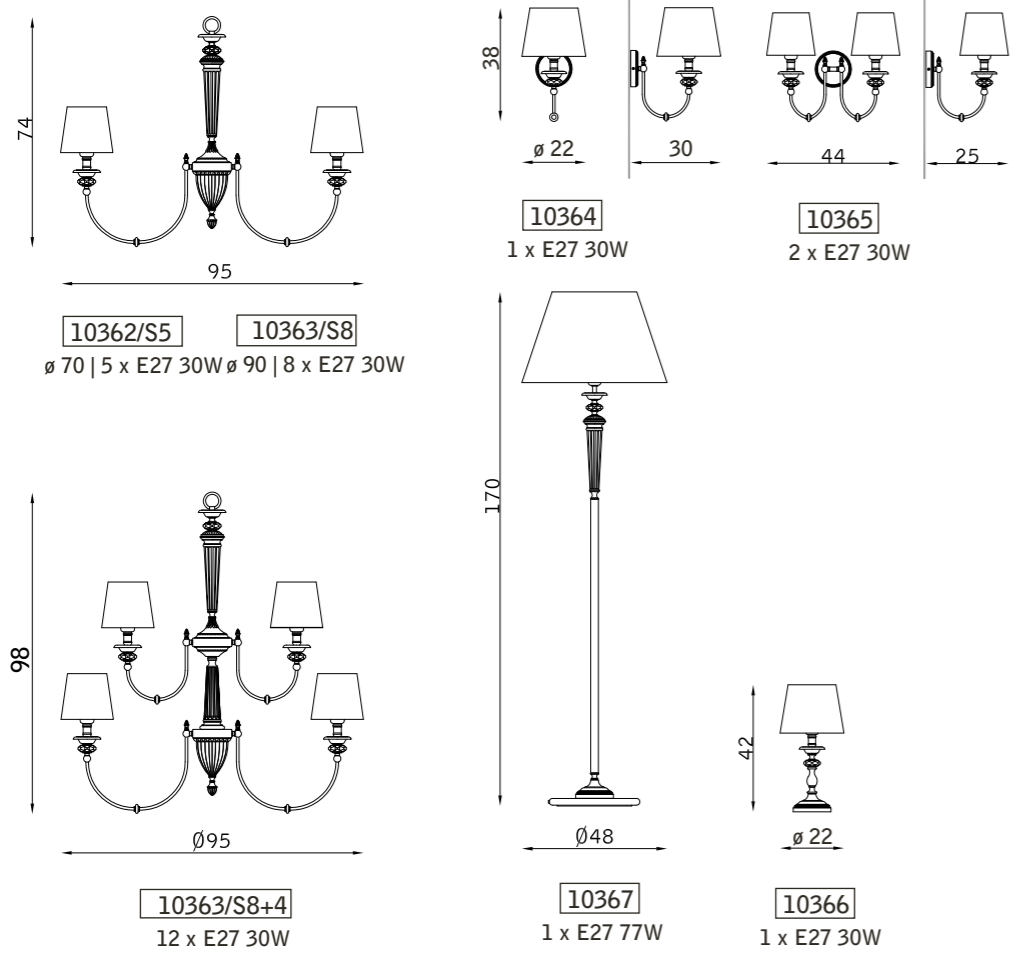

SOFFIO

Venetian blown glass chandelier available in chrome (102) + smoked glass FM, chrome (102) + transparent glass TR, gold (145) + milk ivory glass AL, gold (145) + amber glass AM, or in other colours of your choice.

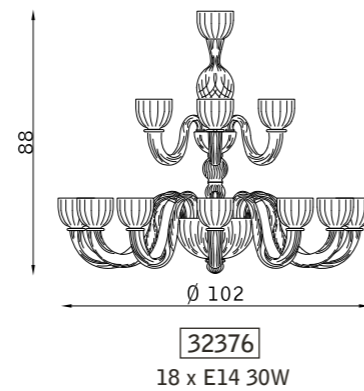
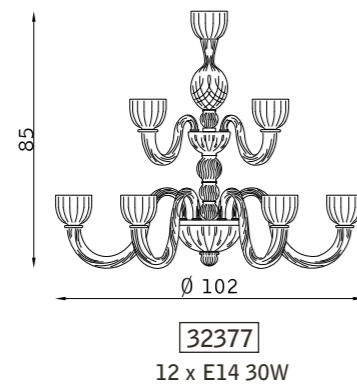
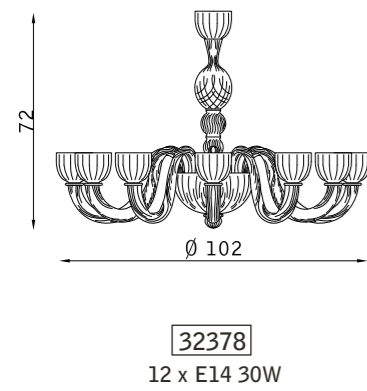
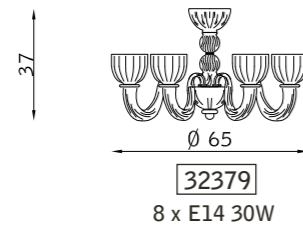
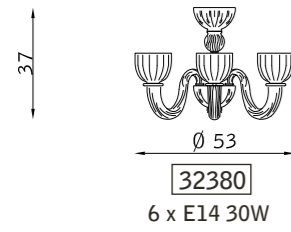

SOFFIO

Venetian blown glass chandelier available in chrome (102) + smoked glass FM, chrome (102) + transparent glass TR, gold (145) + milk ivory glass AL, gold (145) + amber glass AM, or in other colours of your choice.

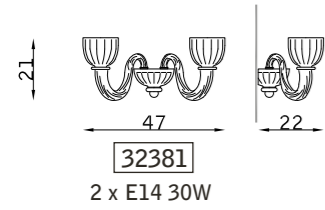

IMPERATRICE

"Maria Teresa" chandelier with chrome parts (102), TR transparent glass facets on the arms and CR lead crystal pendants. Optional lampshades in wool-white (036).

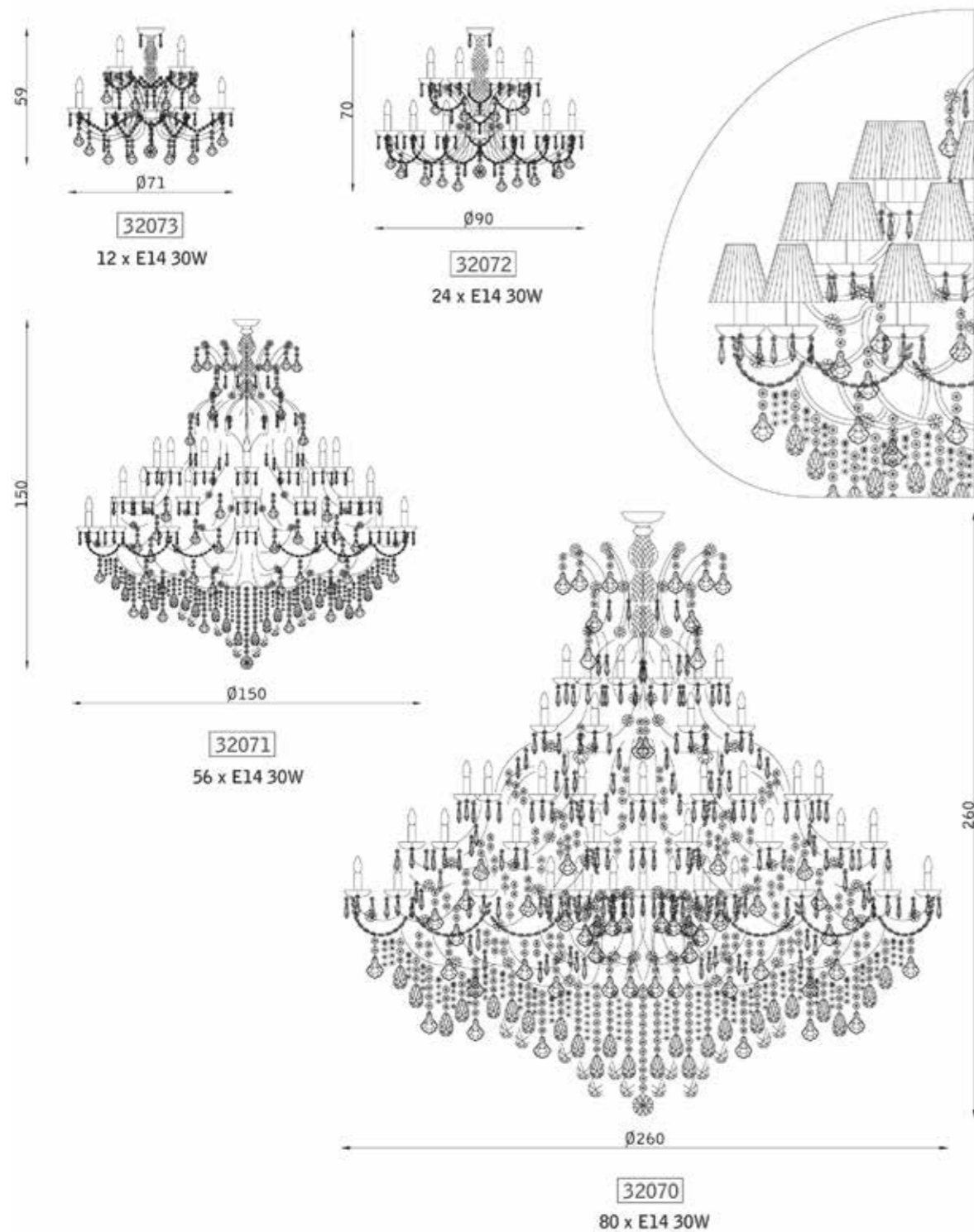

DOGE

Venetian chandelier in blown glass with Cà Rezzonico processing available in transparent glass + silver TR +AR, transparent + gold TR + OR, smoked + gold FM + OR, amethyst + silver AT + AR, with chromed or gold-plated metal mechanics depending on the decoration of the glass.

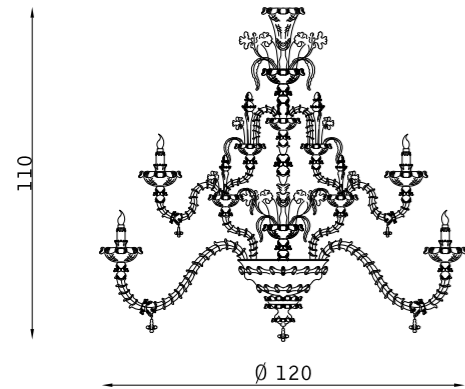

32447

12 x E14 30W

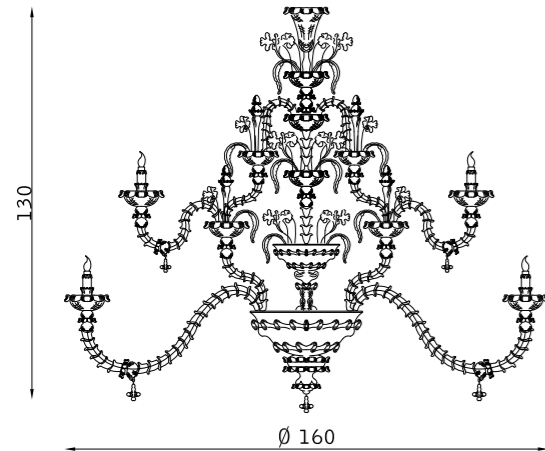

32448

18 x E14 30W

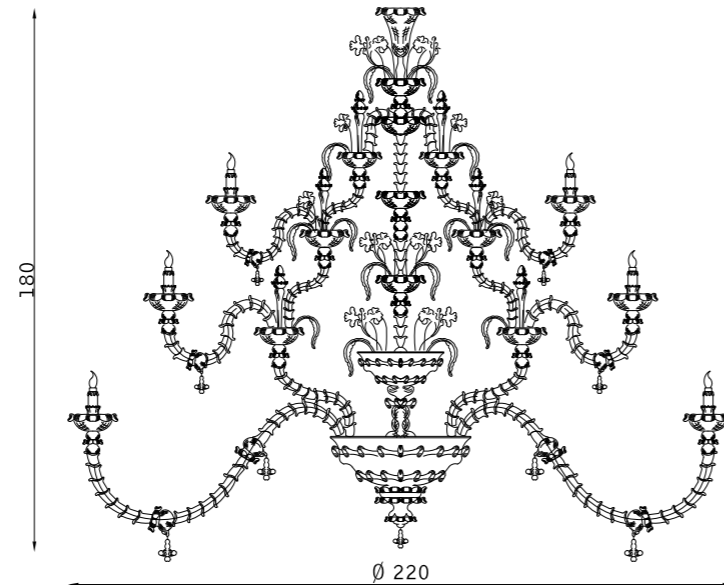

32449

32 x E14 30W



DOGE

Venetian chandelier in blown glass with Cà Rezzonico processing available in transparent glass + silver TR + AR, transparent + gold TR + OR, smoked + gold FM + OR, amethyst + silver AT + AR, with chromed or gold-plated metal mechanics depending on the decoration of the glass.

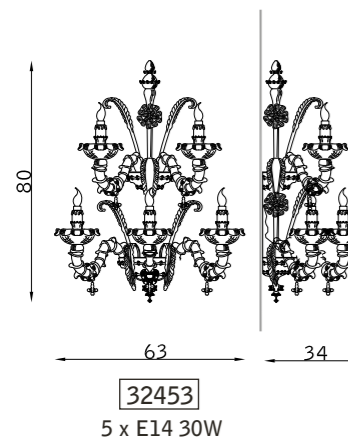
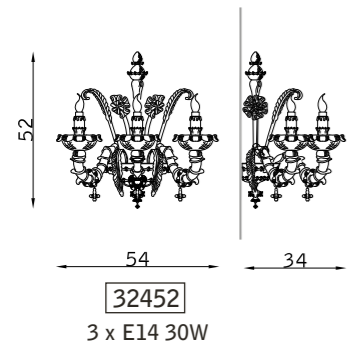
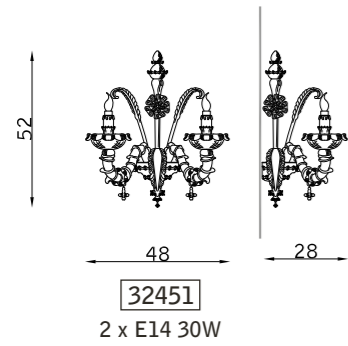



LANTERNA

Brass lamp with worked band and details in cast brass available in french gold (111) finish with curved transparent glass TR, or in other colours of your choice.

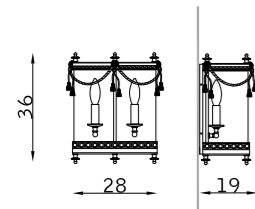

31123
2 x E14 30W

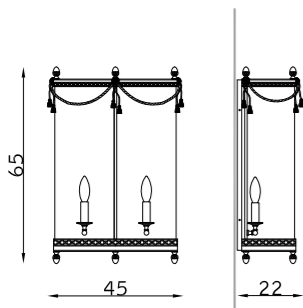

31124
2 x E14 30W

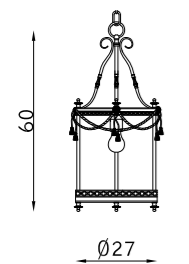

31122
1 x E27 46W

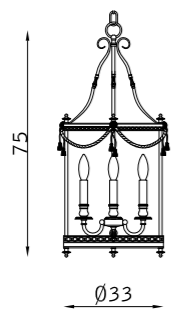

31121
3 x E14 30W

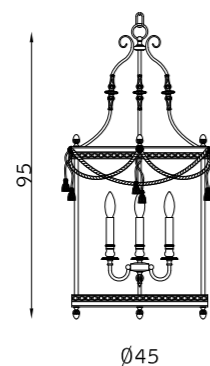

31120
3 x E14 30W

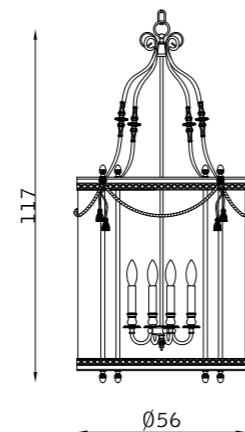

31119
4 x E14 30W



MARE

Metal lamp available in chrome (102) finish with transparent glass TR, or in matt glass, or in other colours of your choice.

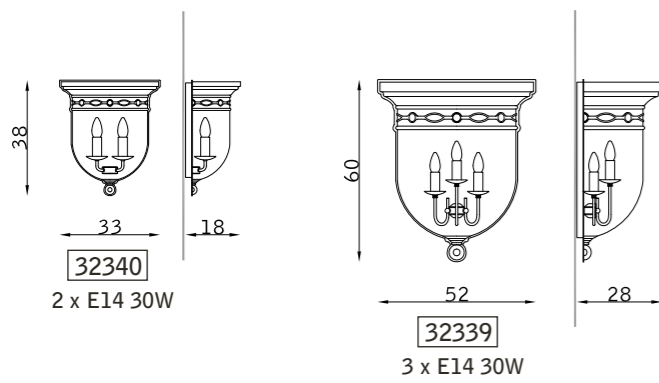
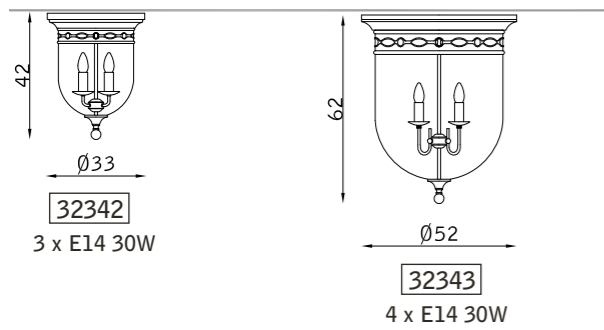
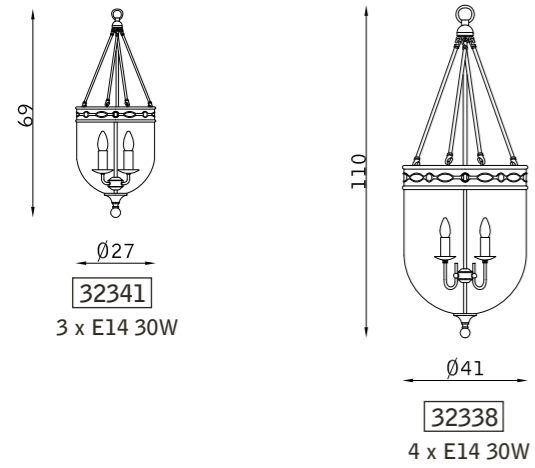

BALLERINA

Lamp with pleated lampshade available in white (090) or black (094) combined with chrome finish (102) and with brown lampshade (095) or ivory (099) combined with gold finish (145), or in other colour combinations of your choice and opal white plexiglass diffuser.

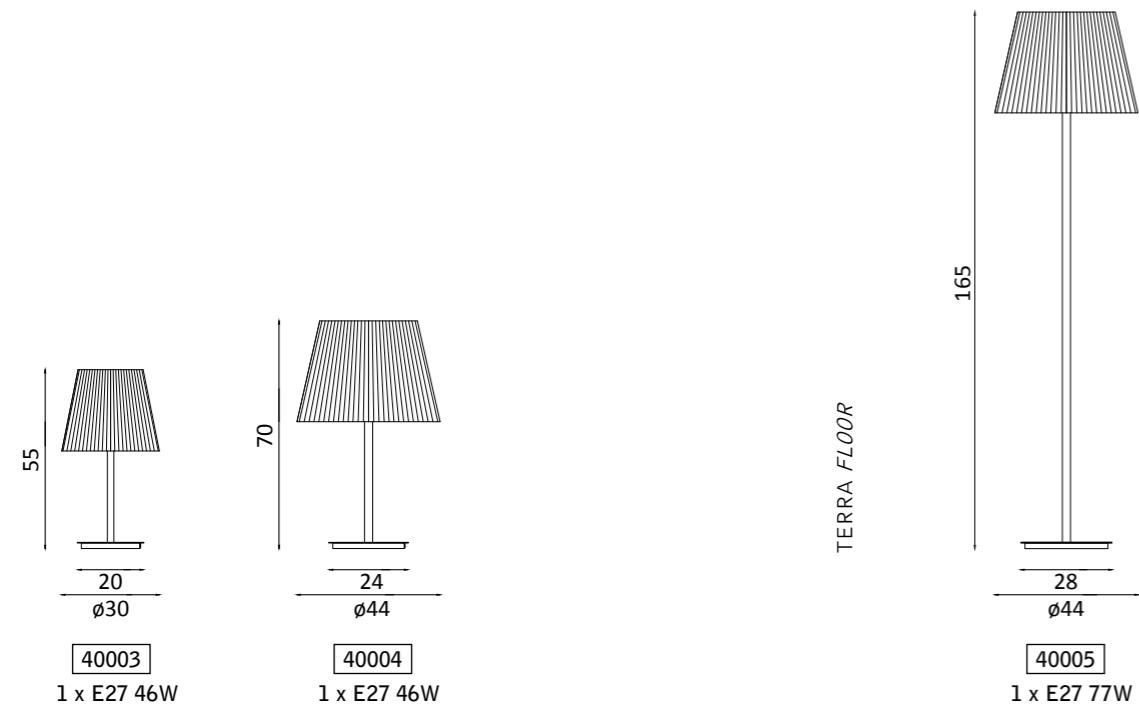
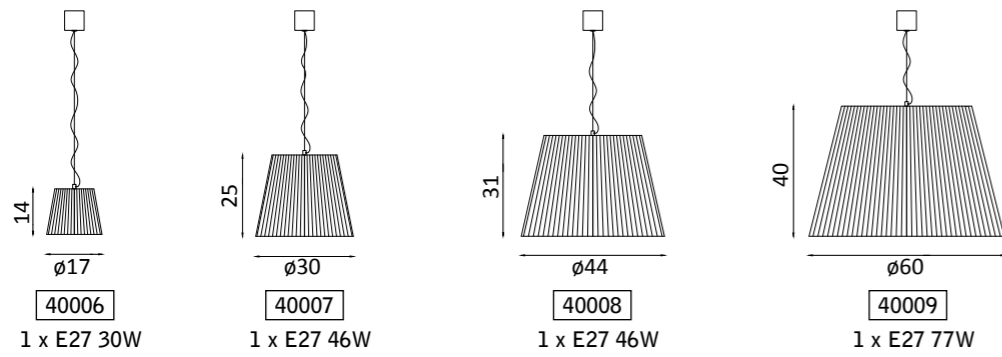
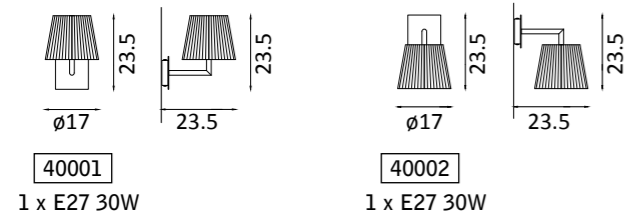

ATMOSFERA

Lead crystal lamp available in polished brass finishes (106) + transparent CR crystal or polished brass (106) + amber decorated CRA crystal, with pleated lampshades in bordeaux (023) or ivory (024), and in other color combinations of your choice.

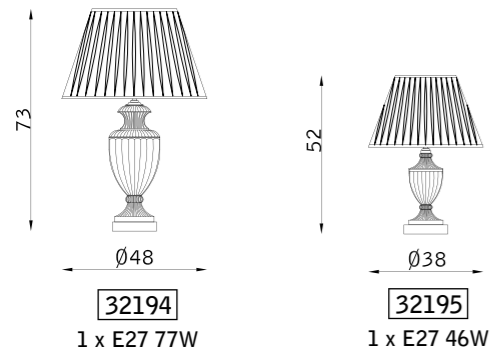

SEMPRE

Lamp with articulated arm, cast brass structure and satin brass finish (120) with pleated ivory (503) lampshade, or in other finishes and colors of your choice.

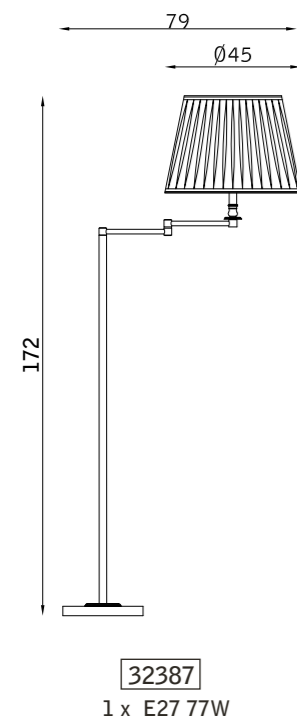
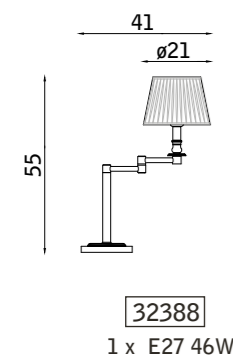
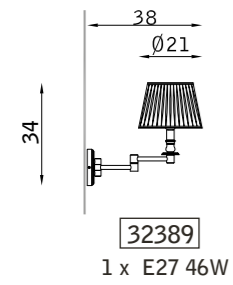

CORINTO

Table lamp in casting brass, bronze video 70 finishing with natural linen shade (LN5).

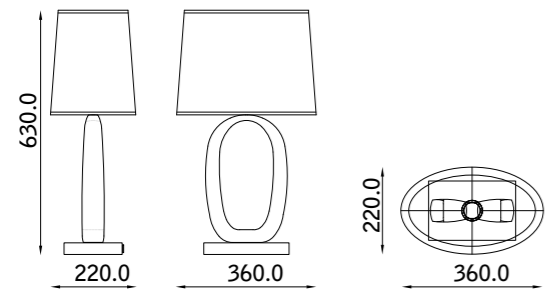

41700
1 x E27 15W



STONE

Table lamp with stone column base, dark bronze details and cotton lampshade customizable in various colors and fabrics.

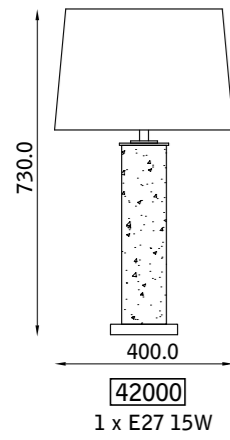

VALENCIA

Ceramic table lamp with a geometrical base structure and cotton lampshade customizable in various colors and fabrics.

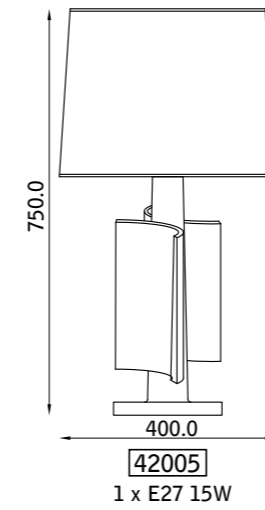

IDRA

Ceramic table lamp with globular vase and cotton lampshade customizable in various colors and fabrics.

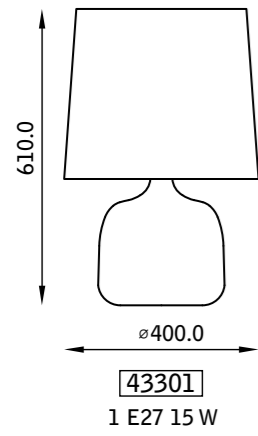

CHIO

Ceramic table lamp with oval-shaped vase and cotton lampshade customizable in various colors and fabrics.

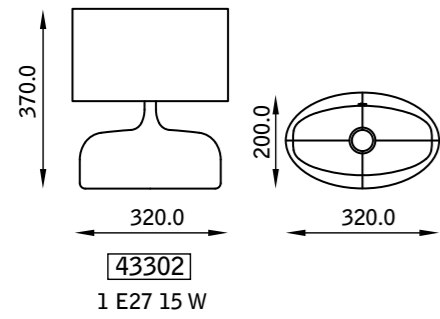

PARO

Ceramic table lamp with cylindrical vase and cotton lampshade customizable in various colors and fabrics.

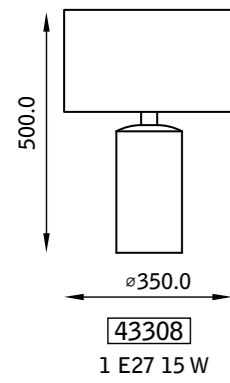

NASSO

Ceramic table lamp with square-shaped vase and cotton lampshade customizable in various colors and fabrics.

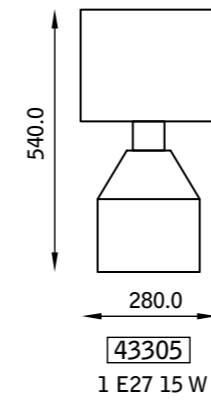

MONACO

Table and floor lamps with central column in walnut finish wood (70), mechanical part in dark bronze (127), ivory (886) smooth lampshade and internal diffuser in white satin glass.

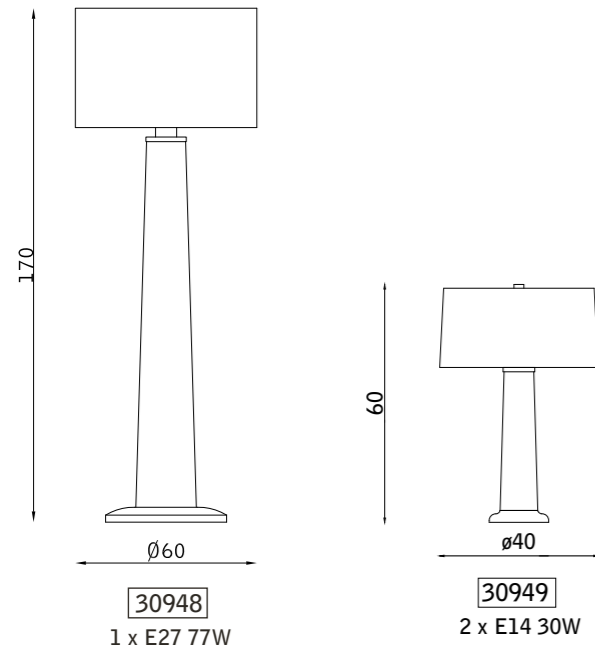

AURA

Special wall lamp, metal structure in brass with bronze video (70) finishing and smooth white glass diffuser.

The single-light version is suitable for bathroom use.

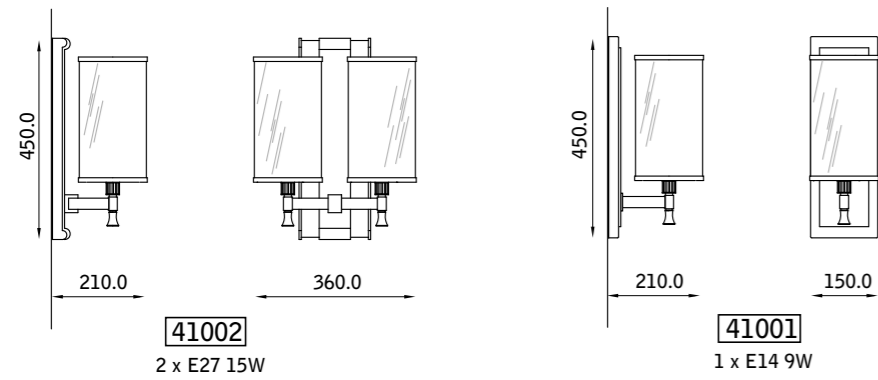

VIENNA

Wall light in metal available in light bronze, dark bronze video 70, chrome and other finish of your choice, with grooved glass diffuser. Suitable for bathroom use.

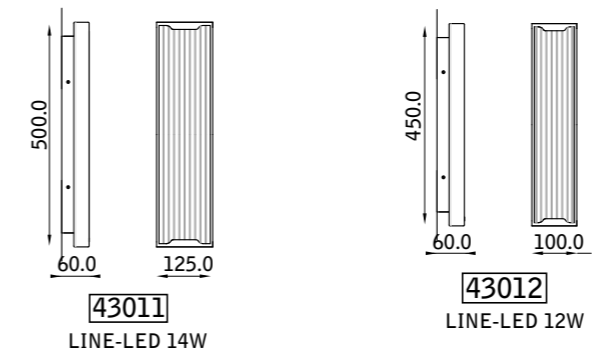

ACQUA

Metal lamp available in chrome finish (102) with satin white plexiglass PBS or dark bronze (127) with satin ivory plexiglass PAS.

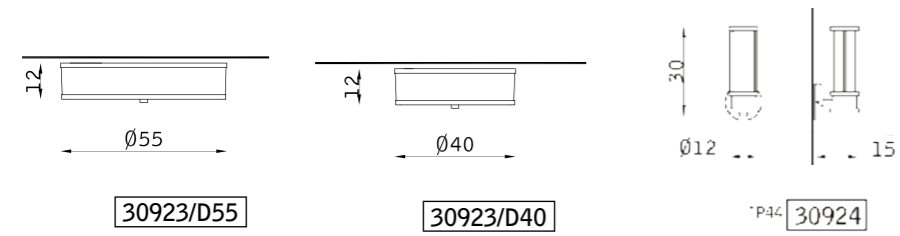

SOGNI

Wall lamp available in polished brass finishes (106) with black gold inside (000IO) smooth lampshade, chrome (102) with white (424) smooth lampshade, dark bronze (127) with ivory (459) smooth lampshade.

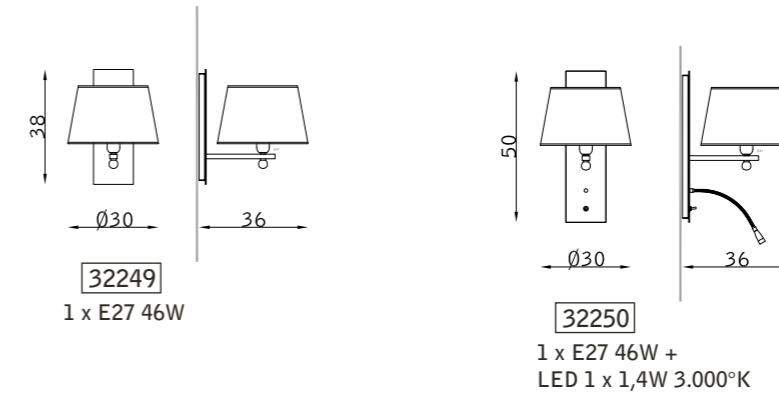

QUADRO

Metal picture lamp available in satin nickel (101) or dark bronze (127) finishing. For items 40185 and 40577, fixing bracket for picture integrated into the base.

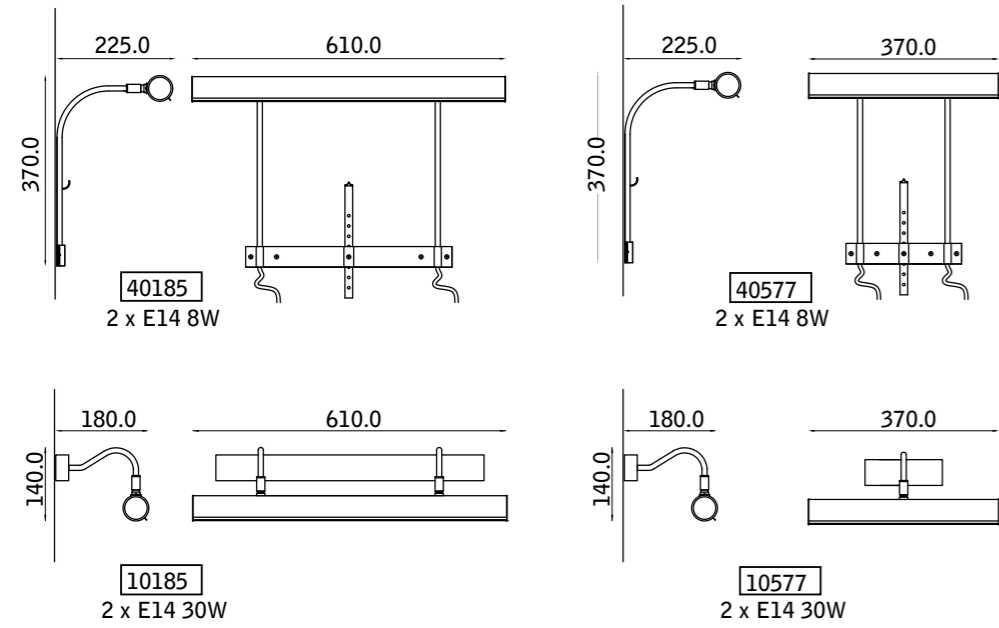

DINAMICA

Wall lamp available in chrome color combinations (102) + grey fabric cover TGR, dark bronze (127) + gold fabric cover TRO, polished brass (106) + black fabric cover TNE, light bronze (126) + brown fabric cover TMA. LED source with concentrated lens to facilitate reading light.

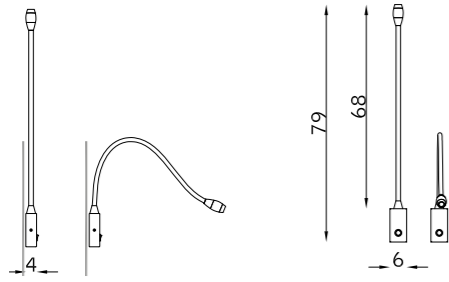

32040

LED 1 x 3,4W 2.900°K - 45°

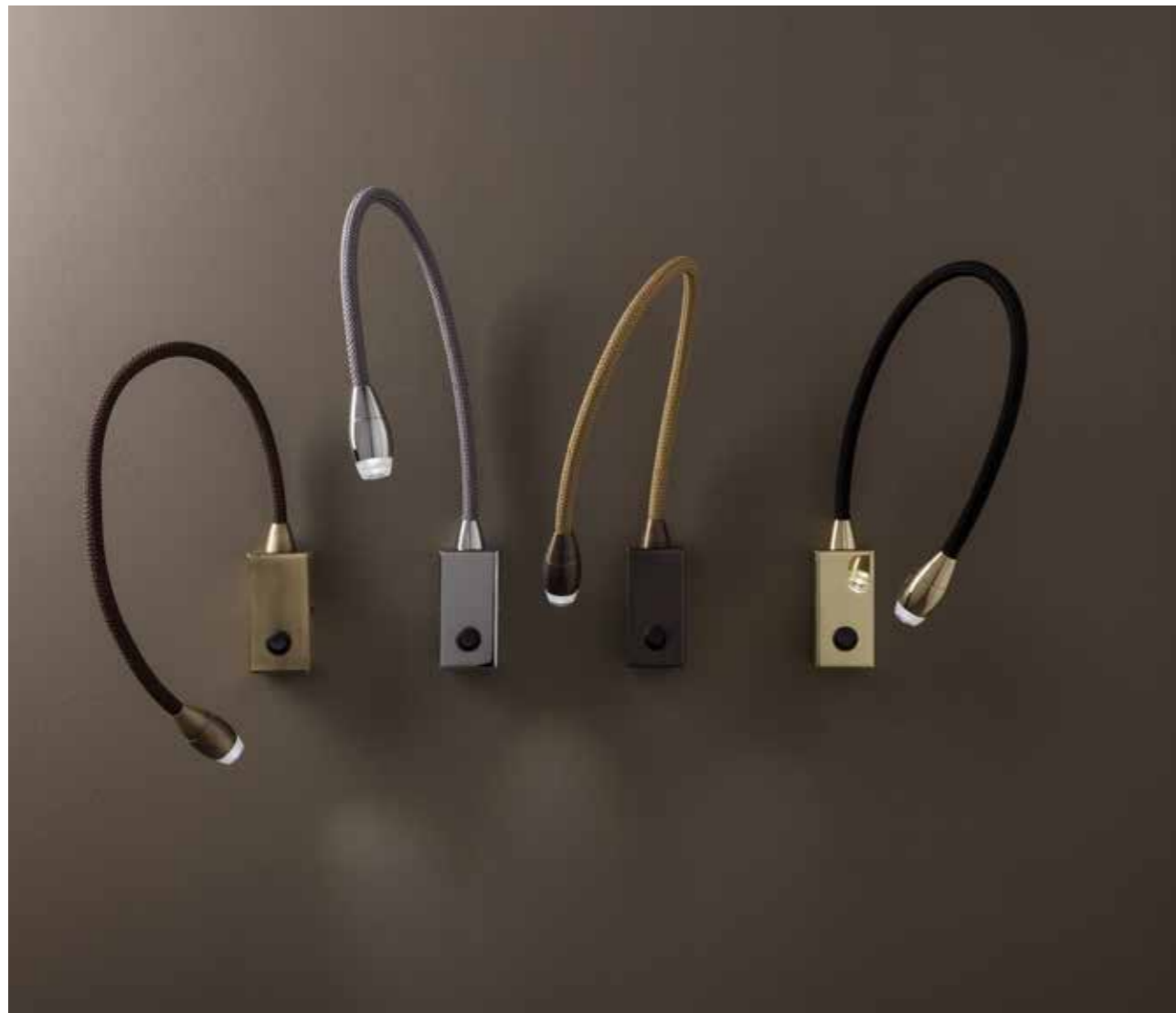

ZONKITA

ZonKita is the battery table lamp from Zonca Lighting, with a satin brass finish and a pleated ivory lampshade. Its 3.5 W LED can be adjusted to three levels of brightness. It has a duration of 12 hours at medium intensity and can be recharged using the special induction charger included, which is also compatible for recharging the latest iPhone devices, or via multiple charging trays. Upon request, Zonkita can be personalized in metal and fabric finish.

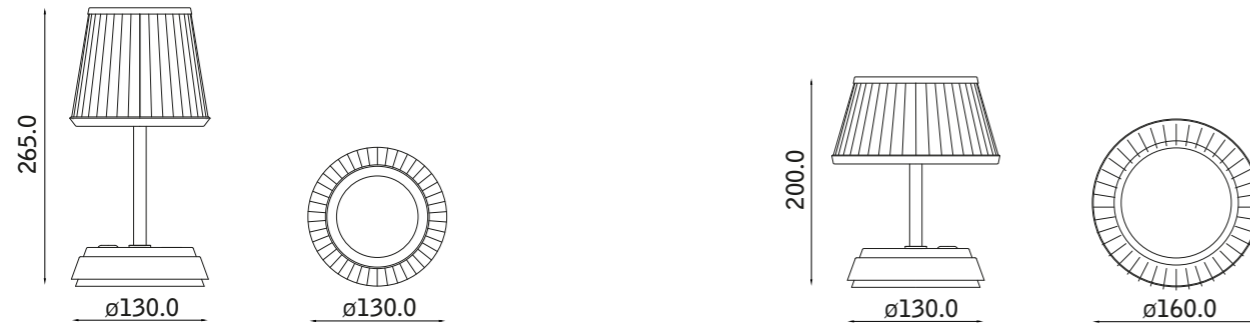

HOW TO REACH US

From the **A7 highway** (Milan/Genoa)

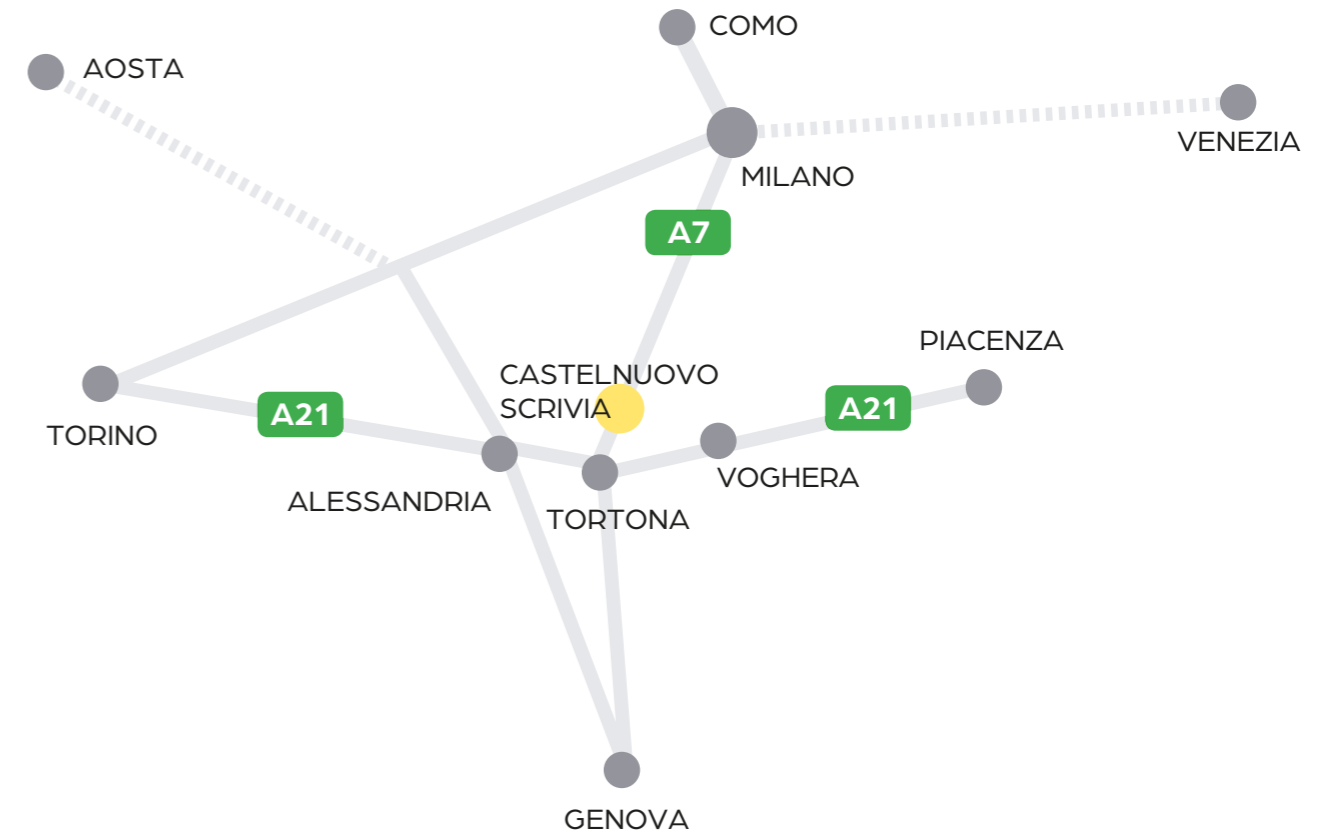

From the **A21 highway** (Turin/Piacenza)
"Voghera" exit, follow road markings to
"Castelnuovo Scrivia".

ZONCA LIGHTING Srl

Headquarter

Via Berri 2/4, 15053
Castelnuovo Scrivia (AL) - Italy

Legal Office

Via Torquato Tasso, 50
24121, Bergamo (BG) - Italy

Tel. + 39 0131 1716750

Email : info@zoncalighting.it

Photos: Luca Casonato

Graphic and print: Art&Coop Castelnuovo Scrivia (AL) – Italy – November 2024

In order to ensure continual technical and functional improvement, Zonca Lighting reserves the right to make minor or significant changes to its products, which may be introduced without prior notice. Designs, dimensions and colours are for indicative purposes only and are not binding for Zonca Lighting. This catalogue is protected by copyright law – Law no. 633 of 22/4/1941 and R.D. no. 1485 of 14/12/1942, as amended, as well as by current laws, regulations and decrees.

Reproduction in whole or in part is prohibited.

Zonca Lighting products comply with all applicable legislation.

